

NESPA ENTERPRISES INC.

2800 Richter Ave. Suite C  
Oroville, CA 95965

Office: (888) 479-4677 Fax: (530) 534-9915  
E-Mail: sales@tiledspas.com www.tiledspas.com

# DUAL INLINE FILTERS

## DETAIL

\*ALL DIMENSIONS SUBJECT TO 1/4" TOLERANCES\*

SCALE: 1/2" = 1'-0"

DATE: 02/04/03

JOB:

DR#:

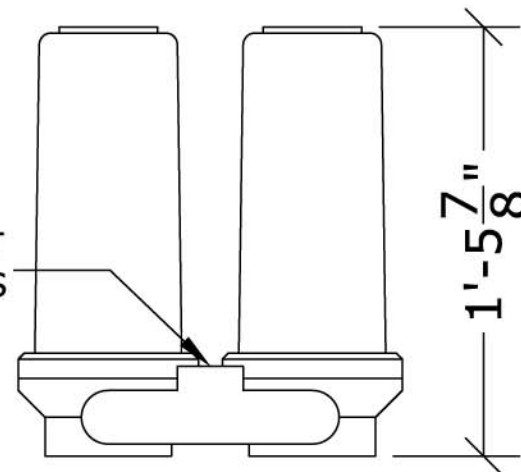
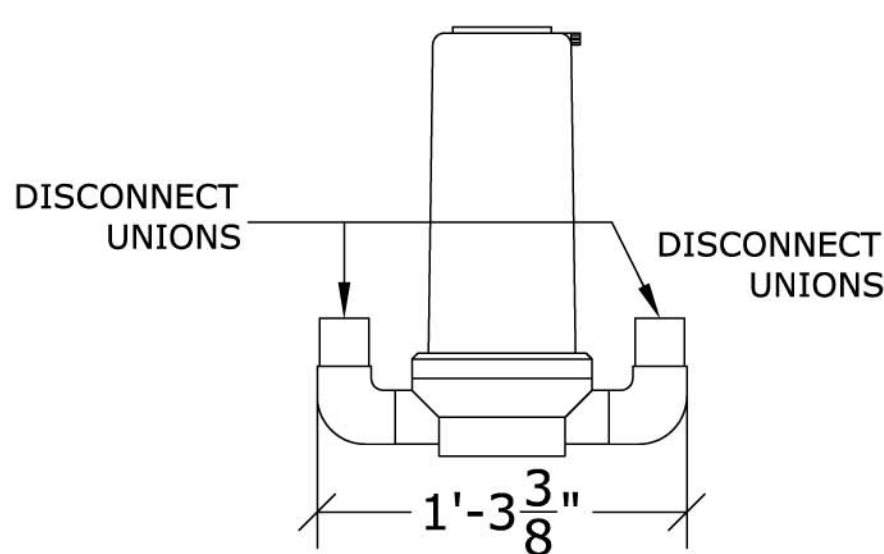
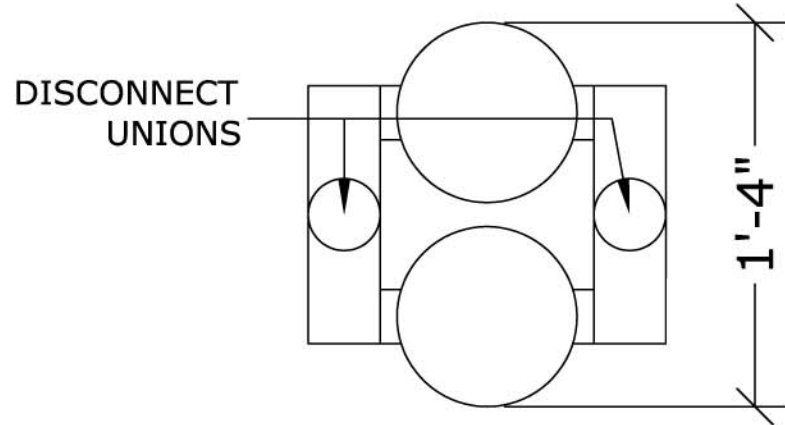

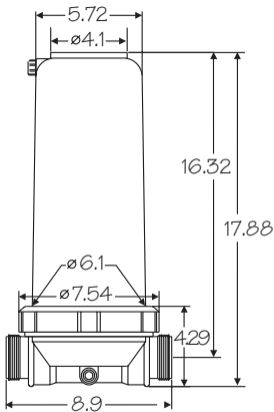

## 1 1/2" FILTER

### PART NO.

500-2560  
500-2570  
500-5060  
500-5070  
500-6060  
500-6070

### PARTS INCLUDED WITH FILTER

25 Sq. Ft. Cartridge, Plug  
25 Sq. Ft. Cartridge, Bypass Valve  
50 Sq. Ft. Cartridge, Plug  
50 Sq. Ft. Cartridge, Bypass Valve  
Plug, W/O Cartridge  
Bypass Valve W/O Cartridge

## 2" FILTER

502-2560  
502-2570  
502-5060  
502-5070  
502-6060  
502-6070

25 Sq. Ft. Cartridge, Plug  
25 Sq. Ft. Cartridge, Bypass Valve  
50 Sq. Ft. Cartridge, Plug  
50 Sq. Ft. Cartridge, Bypass Valve  
Plug, W/O Cartridge  
Bypass Valve W/O Cartridge