

Clean & Clear™ Plus Cartridge Filters Owner's Manual

IMPORTANT SAFETY INSTRUCTIONS READ AND FOLLOW ALL INSTRUCTIONS SAVE THESE INSTRUCTIONS

Table of Contents

SECTION I.	FILTER INSTALLATION	1
SECTION II.	FILTER OPERATION AND CLEANING	3
SECTION III.	TROUBLE SHOOTING	8
SECTION IV.	TECHNICAL DATA	9
WARRANTY	12

WARNING

Before installing this product, read and follow all warning notices and instructions accompanying this filter. Failure to follow safety warnings and instructions can result in severe injury, death, or property damage. Call (800) 831-7133 for additional free copies of these instructions.

Important Notice

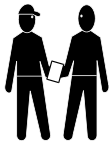

Attention Installer.
This manual contains important information about the installation, operation and safe use of this product. This information should be given to the owner/operator of this equipment.

SECTION I. FILTER INSTALLATION

A. GENERAL INFORMATION

1. The filter should be mounted on a level concrete slab. Position the filter so that instructions, warnings and the pressure gauge are visible to the operator. It also should be positioned so that the piping connections, control valve and drain port are convenient and accessible for servicing and winterizing.

Pentair Pool Products
1620 Hawkins Ave., Sanford, NC 27330 • (919) 774-4151
10951 West Los Angeles Ave., Moorpark, CA 93021 • (805) 523-2400



2. Be certain to install electrical controls (e.g., on/off switches, timers, control systems, etc.) at least five (5) feet from the filter. This permits one to stand clear of the filter during system start up.
3. Allow sufficient clearance around the filter to permit visual verification that the clamp is properly installed around the tank flanges, see Figure A.
 - a. Tap the clamp with a mallet or similar tool to ensure uniform loading during clamp tightening.
4. Allow sufficient space above the filter to remove the filter lid for cleaning and servicing. This distance will vary with the model of filter you are using. See Table 1 for the required vertical clearance.
5. Position the filter to safely direct water drainage. Rotate the High Flow™ manual air relief valve to safely direct purged air or water. Water discharged from an improperly positioned filter or valve can create an electrical hazard as well as damage property.

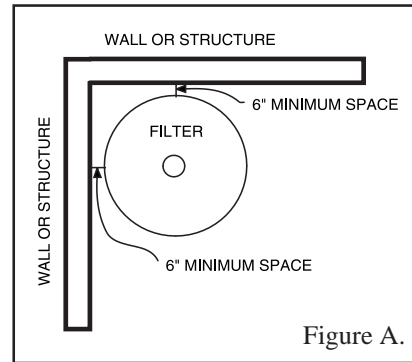

Table 1.

Model No.	P/N	Size	Vert. Clearance Req.
CCP240	160310	240 sq. ft.	56 in.
CCP320	160340	320 sq. ft.	62 in.
CCP420	160301	420 sq. ft.	68 in.
CCP520	160332	520 sq. ft.	74 in.

⚠ WARNING

Risk of electrical shock or electrocution. Position the filter and High Flow™ manual air relief valve to safely direct water drainage and purged air or water. Water discharged from an improperly positioned filter or valve can create an electrical hazard that can cause severe personal injury as well as damage property.

6. Make all plumbing connections in accordance with local plumbing and building codes. Filter plumbing connections are provided with an O-ring seal. Use only a silicone base lubricant on the O-rings. Do not use pipe joint compound, glue or solvent on the bulkhead connections.

NOTE



On threaded valve connections use only Teflon tape, 100% Teflon paste, or Permatex #2 to seal the threads.

7. The maximum working pressure of this filter is 50 p.s.i. Never subject this filter to pressure in excess of this amount, even when conducting hydrostatic pressure tests. Pressures above 50 p.s.i. can cause the lid to be blown off, which can result in severe injury, death or property damage.

When performing hydrostatic pressure tests or when testing for external leaks of the completed filtration and plumbing system, insure that the Maximum Pressure that the filtration system will be subjected to **DOES NOT EXCEED THE MAXIMUM WORKING PRESSURE OF ANY OF THE COMPONENTS CONTAINED WITHIN THE SYSTEM.** In most cases, the maximum pressure will be stated on each component of the system.

If doubt exists as to the pressure to which the system will be subjected, install an ASME approved automatic Pressure Relief or Pressure Regulator in the circulation system for the lowest working pressure of any of the components in the system.

SECTION II. FILTER OPERATION AND CLEANING

 WARNING	
	<p>THIS FILTER OPERATES UNDER HIGH PRESSURE. WHEN ANY PART OF THE CIRCULATING SYSTEM (e.g., FILTER LID, PUMP, FILTER, VALVES, ETC.) IS SERVICED, AIR CAN ENTER THE SYSTEM AND BECOME PRESSURIZED. PRESSURIZED AIR CAN CAUSE THE LID TO BLOW OFF WHICH CAN RESULT IN SEVERE INJURY, DEATH, OR PROPERTY DAMAGE. TO AVOID THIS POTENTIAL HAZARD, FOLLOW THESE INSTRUCTIONS.</p> <ol style="list-style-type: none">1. BEFORE REPOSITIONING VALVES AND BEFORE BEGINNING THE ASSEMBLY, DISASSEMBLY, OR ADJUSTMENT OF THE LID OR ANY OTHER SERVICE OF THE CIRCULATING SYSTEM: (A) TURN THE PUMP OFF AND SHUT OFF ANY AUTOMATIC CONTROLS TO ASSURE THE SYSTEM IS NOT INADVERTENTLY STARTED DURING THE SERVICING. (B) OPEN AIR RELIEF VALVE, AND (C) WAIT UNTIL ALL PRESSURE IS RELIEVED - PRESSURE GAUGE MUST READ ZERO (0).2. WHENEVER INSTALLING THE FILTER LID, FOLLOW THE FILTER LID INSTALLATION INSTRUCTIONS EXACTLY.3. ONCE SERVICE ON THE CIRCULATING SYSTEM IS COMPLETE, FOLLOW SYSTEM RESTART INSTRUCTIONS EXACTLY.4. MAINTAIN CIRCULATION SYSTEM PROPERLY. REPLACE WORN OR DAMAGED PARTS IMMEDIATELY (e.g., lid, knob, pressure gauge, relief valve, O-rings, etc.)5. BE SURE THAT THE FILTER IS PROPERLY MOUNTED AND POSITIONED ACCORDING TO INSTRUCTIONS PROVIDED.

A. GENERAL INFORMATION

1. This filter operates under pressure. When clamped properly and operated without air in the circulating system, this filter will operate in a safe manner.
2. The maximum working pressure of this filter is 50 p.s.i. Never subject this filter to pressure in excess of this amount - even when conducting hydrostatic pressure tests. Pressures above 50 p.s.i. can cause the lid to be blown off, which can result in severe injury, death or property damage.

When performing hydrostatic pressure tests or when testing for external leaks of the completed filtration and plumbing system, insure that the Maximum Pressure that the filtration system will be subjected to **DOES NOT EXCEED THE MAXIMUM WORKING PRESSURE OF ANY OF THE COMPONENTS CONTAINED WITHIN THE SYSTEM.** In most cases, the maximum pressure will be stated on each component of the system.

If doubt exists as to the pressure to which the system will be subjected, install an ASME approved automatic Pressure Relief or Pressure Regulator in the circulation system for the lowest working pressure of any of the components in the system.

3. The pressure gauge is the primary indicator of how the filter is operating. Maintain your pressure gauge in good working order.

⚠ WARNING	
	<p>Your filter is a piece of machinery, do not tamper with it, attempt to disassemble it or otherwise adjust it unless you fully understand it's operation. Serious injury or death can occur if the equipment is improperly handled. Consult a pool service professional for maintenance and service assistance.</p>

4. Clean your filter when pressure reads between 8-10 p.s.i. higher than the original starting pressure. Your filter pressure reading will increase as it removes dirt from your pool. However, this buildup of pressure will vary due to different bathing loads, temperature, weather conditions, etc.
 - a. MY ORIGINAL STARTING PRESSURE IS _____ psi (pounds per square inch). I SHOULD CLEAN THE FILTER CARTRIDGE ELEMENT AT _____ psi.

NOTE

For first time operation on new pools introduce into the system .75 pounds of diatomaceous earth per every 100 square feet of filter area (a one-pound coffee can equals .5 pounds of diatomaceous earth). Mix the diatomite with water and pour it into the skimmer after the pump is primed and the system is operating. This will enhance the filtration of your water.

B. CLAMP INSTALLATION INSTRUCTIONS

These instructions MUST BE FOLLOWED EXACTLY to prevent the lid from blowing off during system restart or later operation:

1. Perform the following procedures before working on any part of the circulating system (e.g., clamp, pump, filter, valves, etc.).
 - a. Turn the pump off and shut off any automatic controls to ensure that the system is not inadvertently started during servicing.
 - b. Open the High Flow™ manual air relief valve.
 - c. Wait until all pressure is relieved. **Never attempt to assemble, disassemble or adjust the filter clamp while there is any pressure in the filter.**
2. Be certain the O-ring is in position in the lower tank half. Place the filter lid over the lower tank half sandwiching the O-ring in between.
3. Holding the ends of the filter clamp apart, position the center segment of the filter clamp over both upper and lower tank flanges. Bring the ends of the filter clamp together and insert the T-Bolt into the trunnion; see Figure B.
4. Using Figure B as a guide, place washer and tension-indicating spring/nut on T-Bolt. Hand-tighten nut. Recheck filter clamp for proper seating on tank flanges.

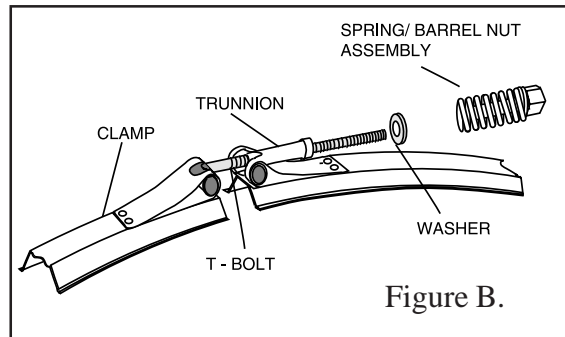

5. Begin to tighten nut using a 7/8" wrench. Then tap around the outside of the filter clamp with a mallet (or similar tool) to insure uniform loading and proper seating of the clamp. Continue tapping and tightening until the spring coils touch each other. Do not tighten beyond this point.
6. Follow the procedures in Section C, System Restart Instructions.
7. The spring coils should be checked at least once per month to ensure that they continue to touch each other, indicating that the clamp is under sufficient tension. If coils fail to touch repeat Step B.5 in this section, above.

C. SYSTEM RESTART INSTRUCTIONS

⚠ WARNING	
	<p>THIS FILTER OPERATES UNDER HIGH PRESSURE. WHEN ANY PART OF THE CIRCULATING SYSTEM (e.g., CLAMP, PUMP, FILTER, VALVES, ETC.) IS SERVICED, AIR CAN ENTER THE SYSTEM AND BECOME PRESSURIZED. PRESSURIZED AIR CAN CAUSE THE LID TO BE BLOWN OFF WHICH CAN RESULT IN SEVERE INJURY, DEATH, OR PROPERTY DAMAGE. TO AVOID THIS POTENTIAL HAZARD, FOLLOW THESE INSTRUCTIONS.</p>

1. **Open the High Flow™ manual air relief valve until it snaps into the full open position (this only requires a quarter turn counter-clockwise).** Opening this valve rapidly releases air trapped in the filter.
2. Stand clear of the filter tank, then start the pump.
3. Close the High Flow™ manual air relief valve after a steady stream of water appears.
4. The system is not working properly if either of the following conditions occur.
 - a. A solid stream of water does not appear within 30 seconds after the pump's inlet basket fills with water.
 - b. The pressure gauge indicates pressure before water outflow appears.

If either condition exists, **shut off the pump immediately**, open valves in the water return line to relieve pressure, and clean the air relief valve, see Section F, Cleaning the High Flow™ manual air relief valve. If the problem persists, call (800) 831-7133 for assistance.

D. CLEANING FILTER MANUALLY

⚠ WARNING	
	<p>Operating the filter system without filter internal components installed can allow air to accumulate within the filter. Pressurized air can cause the lid to blow off which can result in severe injury, death or property damage. Always operate filter system with filter internal components installed.</p>

⚠ CAUTION	
<p>The following information should be read carefully since it outlines the proper manner of care and operation for your filter system. As a result of following these instructions and taking the necessary preventative care, you can expect maximum efficiency and life from your filtration system.</p>	

1. Turn the pump off, shut off any automatic controls to ensure that the system is not inadvertently started during servicing.
2. Open the filter High Flow™ manual air relief valve (and the waste drain valve or plug, if your system has one).
3. Remove hair and lint strainer pot lid and clean basket. Replace basket and secure lid.
4. Disconnect air relief valve drain hose if installed.
5. Release tank clamp assembly and remove tank lid.
6. Remove top manifold and cartridge element separately.
7. Using a garden hose without a nozzle, direct water spray at cartridge element to dislodge and wash away accumulated foreign matter. Flush each cartridge inside-out.

WARNING



Please heed all manufacturers' posted instructions, warnings and cautions when using Baquacil® or Baqua Clean®.

NOTE

Special care must be taken when cleaning filter cartridges used in a swimming pool or spa using Baquacil as a sanitizer. Because of the way Baquacil works, the filter element must be cleaned more thoroughly and more frequently than in a chlorine system. If extreme care is not taken to completely remove all residue from the filter media a buildup will occur. This buildup will significantly shorten the life of the filter element.

Baquacil is a mild coagulant which combines bacterial cells as well as other small particles contributed by the environment, bathers, etc. into particles large enough to be trapped by the filter. In comparison with all other trapped contaminants in a typical pool or spa the amount of bacterial cells that are deposited on the filter is minimal. The resulting deposit is a gray sticky film which can only be removed with Baqua Clean. If TSP or any TSP-type cleaner is used prior to stripping the film, the cleaner and the gray film will combine to form a gum-like substance. Once this occurs, the substance cannot be removed from the media and the filter cartridge must be replaced.

8. Lift bottom manifold out of the tank and flush off any debris.
9. Direct water spray to wash out the inside of the tank body. Water and debris will drain out through the open drain port.
10. Check gasket around outer lip of bottom plate. Gasket must be firmly and evenly set in place. Coat generously with a silicone base lubricant. Do not use petroleum base lubricants to avoid damage to the gasket.

NOTE

Any time the filter tank is opened and/or element assembly is removed, be sure to generously coat the bottom plate sealing ring and the tank O-ring gasket with silicone lubricant before reassembling the unit. Do not use petroleum base lubricants because they have a deteriorating effect on rubber.

11. Place bottom manifold, 4 cartridges, top manifold and air relief tube in place. Make sure the spring and standpipe assembly are retained on the top manifold. Ensure the air relief tube stays in an upright position. This is essential for the maximum air removal from inside the tank.
12. Be certain the O-ring is in position in the lower tank half. Coat it generously with a silicone base lubricant. Press the filter lid over the lower tank half and sandwich the O-ring in between.
13. Replace tank top and carefully follow instructions in Section B, Clamp Installation Instructions.
14. Replace drain plug and reinstall air relief valve drain hose if used.

E. REPLACING FILTER CARTRIDGES

Filter cartridge element life will vary with pool conditions such as bather load, wind, dust, etc. You can expect an average cartridge life of 3 years under normal conditions.

1. To replace cartridge element follow steps in Section D, Cleaning Filter, eliminating step D.7.

NOTE

Any time the filter tank is opened and/or element assembly is removed, be sure to generously coat the bottom plate sealing ring and the tank O-ring gasket with silicone lubricant before re-assembling the unit. Do not use petroleum base lubricants because they have a deteriorating effect on rubber.

F. CLEANING THE HIGH FLOW™ MANUAL AIR RELIEF VALVE

1. Turn the pump off and shut off any automatic controls to ensure that the system is not inadvertently started during servicing.
2. **OPEN THE HIGH FLOW™ MANUAL AIR RELIEF VALVE UNTIL IT SNAPS INTO THE FULL OPEN POSITION, THEN WAIT UNTIL ALL PRESSURE IS RELIEVED.**
3. With the relief valve attached to the filter tank, pull out the locking tabs and remove the valve stem and cover assembly with a counter-clockwise and lifting motion, see Figure C.
4. Clean debris from the valve stem and body. Verify that the filter tank's air passage is open by inserting a 5/16" drill bit through the valve body. Verify that the O-rings are in good condition, properly positioned, and lubricated with a silicone base lubricant.
5. Reinstall the valve stem and cover assembly with a downward and clockwise motion until it snaps into position.

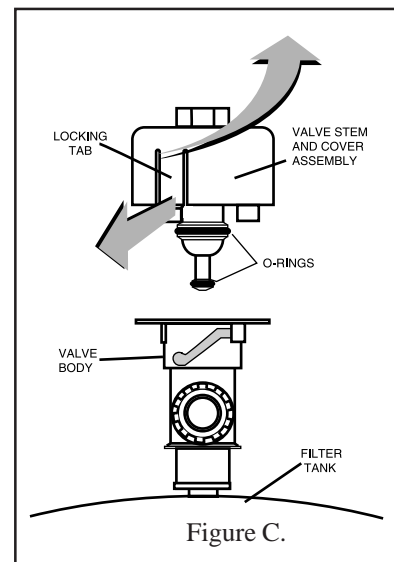

SECTION III. TROUBLE SHOOTING

- A. Air entering your filter is dangerous and can cause the lid to blow off. Correct any conditions in your filtration system that allow air to enter the system.
 - 1. Some common ways to identify air entering the system:
 - a. Low water level in pool or spa - skimmer is starving for water with pump running. Add water to pool or spa.
 - b. Air bubbles or low water level in pump hair and lint pot are caused by; low water level, clogged skimmer basket, split suction cleaner hose, leak in pump hair and lint pot lid, or leak in pump suction line.
 - c. Air bubbles coming out of water return lines into pool or spa with pump running, see items 1.a and 1.b of this section.
 - d. Air is discharged from the air relief valve on top of the filter when the valve is opened with the pump running, see items 1.a and 1.b of this section, above.
- B. Until the water initially put into the pool has been completely filtered, short filter cycles in between cleanings are normal. In most cases pool owners are dismayed by the undesirable color and appearance of water in a newly filled pool. Plaster dust can be responsible for short filter cycles, requiring frequent cleaning.
- C. If pressure drops on gauge, check skimmer basket and pump basket first for debris. If the baskets are clean, shut off power to pump and turn off any automatic controls. Then turn motor shaft with your fingers. If it turns freely then the pump must be disassembled and the impeller checked to see if it is clogged. If it is not frozen or clogged then there is an obstruction in the line between the pool and the pump.
- D. The pressure gauge is an important part of the filter system. It is your primary indicator of how the system is operating. Maintain your pressure gauge in good working order. Check the operation of your pressure gauge in the following manner:
 - 1. The pressure gauge should go to zero (0) when the system is turned off and pressure is relieved.
 - 2. The pressure gauge should indicate pressure when the system is operating.
 - 3. The pressure gauge should be readable and not damaged in any way.
 - 4. Replace the pressure gauge if it is not meeting the requirements of items D.1 through D.2 of this section, above.

SECTION IV. TECHNICAL DATA

A. FLOW RATES

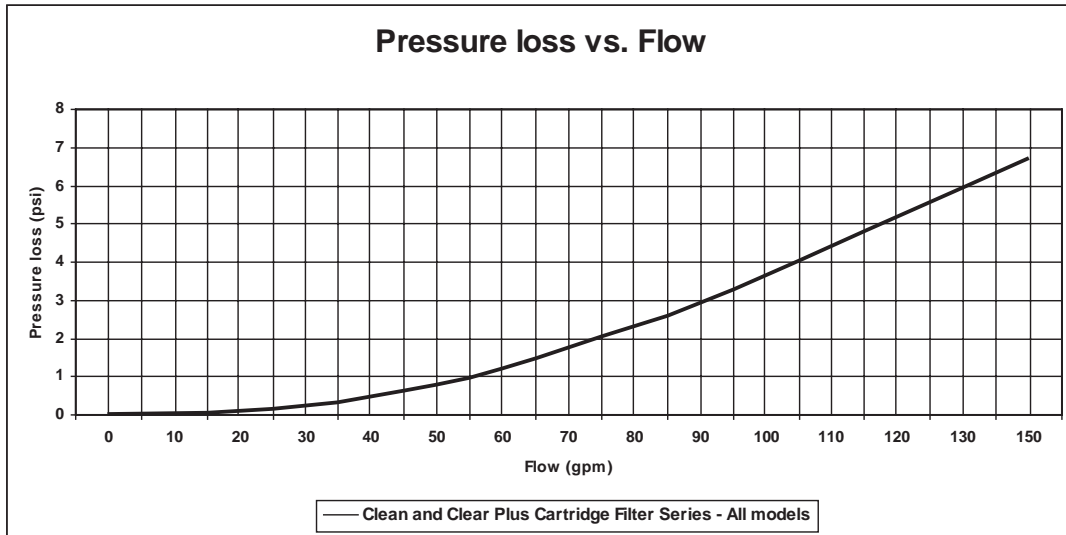

Clean & Clear Plus Cartridge Filters								
Recommended Flow Rate								
Product #	Model #	Filter Area sq. ft.	Vertical* Clearance	Flow Rate GPM		Turnover Capacity in Gallons		
				Res.	Comm.	6 hours	8 hours	12 hours
160310	CCP240	240	56 in.	90	90	32,400	43,200	64,800
160340	CCP320	320	62 in.	120	120	43,200	57,600	86,400
160301	CCP420	420	68 in.	150	150	54,000	72,000	108,000
160332	CCP520	520	74 in.	150	150	54,000	72,000	108,000

NOTE: Actual system flow will depend on plumbing size and other system components.

* Required Clearance to remove filter elements.

B. CLEAN & CLEAR PLUS TANK ASSY.

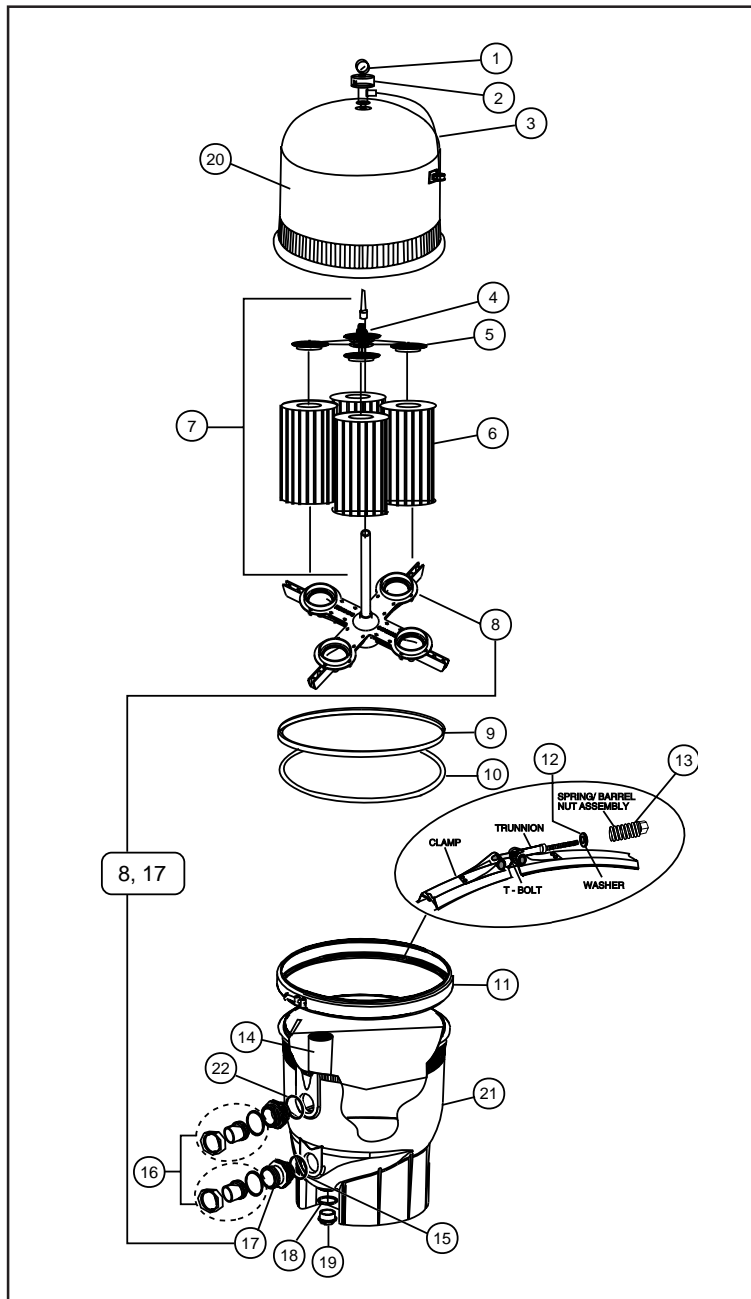

SAVE THESE INSTRUCTIONS.

B. CLEAN & CLEAR PLUS TANK ASSY., contd.

Replacement Parts

Item No.	Part No.	Description
1	53003201	Gauge, pressure, ¼ in.
2	98209800	High Flow™ manual air relief valve (HFMARV)
3	98201200	Hose and retainer clips for HFMARV (Optional accy.)
4	56636900	Spring, compression ❶
4	178616	Spring, compression ❷
5	59071000	Manifold, top assy. ❶
5	170026	Manifold, top assy., 240 sq. ft. ❷
5	170027	Manifold, top assy., 320 & 520 sq. ft. ❷
6	R173572	Cartridge Element, 240 sq. ft., 4 req. ❷
6	R173573	Cartridge Element, 320 sq. ft., 4 req. ❶
6	R173574	Cartridge Element, 360 sq. ft., 4 req. ❷
6	R173575	Cartridge Element, 420 sq. ft., 4 req. aqua end caps ❶
6	R173576	Cartridge Element, 420 sq. ft., 4 req. ❷
6	R173577	Cartridge element, 520 sq. ft., 4 req. ❶
6	R173578	Cartridge element, 520 sq. ft., 4 req. ❷
7	170030	Air bleed tube assy., 240 sq. ft.
7	55028500	Air bleed tube assy., 360, 420 sq. ft. ❶
7	170029	Air bleed tube assy., 320 sq. ft. ❷
7	170028	Air bleed tube assy., 420 sq. ft. ❷
7	55028400	Air bleed tube assy., 500 sq. ft. ❶
7	178583	Air bleed tube assy., 520 sq. ft. ❷
8	56626800	Manifold, bottom ❶
8	170035	Manifold, bottom/pipe assy., outlet ❸
8	170040	Manifold, bottom ❷
9	57000300	Gasket, bottom manifold ❶
10	39010200	O-ring, clamp
11	190003	Clamp kit, tension control
12	53006300	Washer, .325 i.d. for filter clamp
13	53108900	Spring/barrel nut assy.
14	55035000	Baffle, bulkhead assy. ❶
14	190039	Baffle, bulkhead assy. ❷
15	86006900	O-ring, bulkhead, lower
16	98960311	Bulkhead union, (set) ❶
16	271096	Bulkhead union, 1 ½ in. x 2 in. (set), white ❷
16	270004	Bulkhead union, 1 ½ in. x 2 in. (set), black ❷
17	59019200	Pipe assy., outlet ❶
17	170035	Pipe assy., outlet/manifold, bottom ❸
17	170025	Pipe assy., outlet ❷
18	51005000	O-ring for drain plug
19	86202000	Plug, 1-1/2 in. drain with O-ring
20	170023	Tank, lid assy., 240 sq. ft.
20	170024	Tank, lid assy., 320 sq. ft.
20	178552	Tank, lid assy., 360 sq. ft.
20	178551	Tank, lid assy., 420 sq. ft. ❶
20	178581	Tank, lid assy., 420 sq. ft. ❷
20	178550	Tank, lid assy., 500 sq. ft. ❶
20	178582	Tank, lid assy., 520 sq. ft. ❷
21	178559	Tank, bottom assy. ❶
21	178578	Tank, bottom assy. ❷
22	86006900	O-ring, bulkhead, upper ❶
22	192320	O-ring, bulkhead, upper ❷
	192019	Drain plug wrench

❶	Before	11/98
❷	After	11/98
❸	Between	11/98 thru 12/00
❹	After	12/00

Clean & Clear™ Plus Cartridge Filter Limited Warranty

Pentair Pool Products manufactures its Clean & Clear™ Cartridge Filter under high standards of workmanship and with high quality materials. Accordingly, Pentair Pool Products expressly warrants those filter models as follows:

WARRANTY COVERAGE - All internal components of Pentair Pool Products Clean & Clear™ filters (except cloth materials whether synthetic or natural) which are actually manufactured by Pentair Pool Products are warranted to be free from defects in material and/or workmanship for a period of three (3) years from date of purchase. In addition, the tanks of such filters are warranted to be free from defects in material and/or workmanship for a period of ten (10) years from date of purchase. The obligation of Pentair Pool Products under this warranty will be limited to either repair or replacement of the filter tank, at Pentair Pool Products option.

EXCLUSIONS FROM THIS WARRANTY - This warranty does not cover:

1. Any cloth materials, synthetic or natural, contained in the filter.
2. Any item manufactured by other companies and installed by Pentair Pool Products (such as air or water valves, gauges, plumbing fittings, pipes, bolts, nuts, cartridges, etc.)
3. Problems resulting from oversizing of pump and/or reduction of valve piping size, or from failure to turn pump off before changing the position of the filter valve or any operating valves for the pool and its accessories.
4. Problems resulting from failure to comply with instructions contained in the Owners Manual.
5. Problems resulting from abuse, misuse, negligence or accident by any party other than Pentair Pool Products.
6. Problems resulting in whole or in part from alteration or modification of the filter by any party.
7. Failures due to chemical corrosion caused by failure to maintain the water chemistry in conformity with the standards of the swimming pool industry.

WARRANTY OBLIGATIONS OF PENTAIR POOL PRODUCTS - Should a defect in workmanship and/or material in any item covered by this warranty become evident during the term of the warranty, then upon the consumer following the procedures set forth below, Pentair Pool Products will, at its option, repair or replace such item or part at its own cost and expense. Pentair Pool Products is not, however, responsible under this warranty for any cost of shipping or transportation of the filter or part thereof to or from the service department. Also, Pentair Pool Products is not liable for any loss of time, inconvenience, incidental expenses such as telephone calls, labor or material charges incurred in connection with the removal or replacement of the equipment, or any other incidental or consequential damages. **PLEASE NOTE:** Some states do not allow the exclusion or limitation or incidental or consequential damages, so the above limitation or exclusion may not apply to you.

PROCEDURE FOR OBTAINING PERFORMANCE: In order to obtain the benefits of this warranty the consumer who made the original retail purchase will contact Pentair Pool Products Customer Service Department, 10951 West Los Angeles Ave., Moorpark, CA 93021 as soon as possible after discovery of the defect, but in no event later than the expiration date of the warranty period provided in this warranty. Upon receipt of this communication, Pentair Pool Products will promptly notify the customer of the address to which the defective item may be shipped. The customer shall then ship the item, freight prepaid, to the address indicated together with a letter stating the model number, serial number, and the date of purchase of the item which is claimed to be defective, and the name and address of the consumer and a brief description of the problems encountered.

WARRANTY PROTECTS ORIGINAL PURCHASER: This warranty extends to the consumer who made the original retail purchase only and is not enforceable by any other party.

WARRANTIES OR REPRESENTATIONS BY OTHERS: No dealer or other person has any authority to make any warranties or representations concerning Pentair Pool Products or its products. Accordingly, Pentair Pool Products is not responsible for any such warranties or representations.

OTHER RIGHTS: This warranty gives you specific legal rights and you may also have other rights which vary from state to state.

Pentair Pool Products
1620 Hawkins Ave., Sanford, NC 27330 • (919) 774-4151
10951 West Los Angeles Ave., Moorpark, CA 93021 • (805) 523-2400

